

Compliance with Building Regulations when installing or repairing a chimney or re-thatching a roof that abuts a chimney

The increasing problem of thatch fires

Over the last few years the UK has seen a steady increase in the number of chimney related thatched roof fires. Traditionally chimneys in older thatched properties were used with open fires which when in operation had large amounts of cool air from the room the fire was situated in, mixing with the combustion product and cooling the overall flue gas temperature. With the recent drive for efficiency the use of closed room heaters has become more common, whilst these are more efficient and provide far more heat into the room than an open fire, they don't have the benefit of cool room air mixing with the exhaust gases to reduce the flue gas temperature. The knock on effect from this is that chimneys that worked reliably for many years with an open fire are experiencing problems of elevated temperatures when closed stoves are fitted.

The source of the problem

The National Society of Master Thatchers have already reported more than 79 thatch fires in the year to October 2009 with the majority being caused by chimney related problems when used with a multi fuel or wood burning stove. The NSMT have carried out extensive research into how a thatch fire starts and besides the obvious transmission of hot flue gases through a brick stack with open or porous joints, their evidence also points towards the presence of thick beds of thatch against chimneys together with high flue gas temperatures, which over time allow the thatch to be heated to a point where it will char or burn. The thatch is effectively insulating the brick chimney stack preventing the release of heat from the brickwork and creating a localised hot spot in the centre of the thatch as detailed in Figure 1.

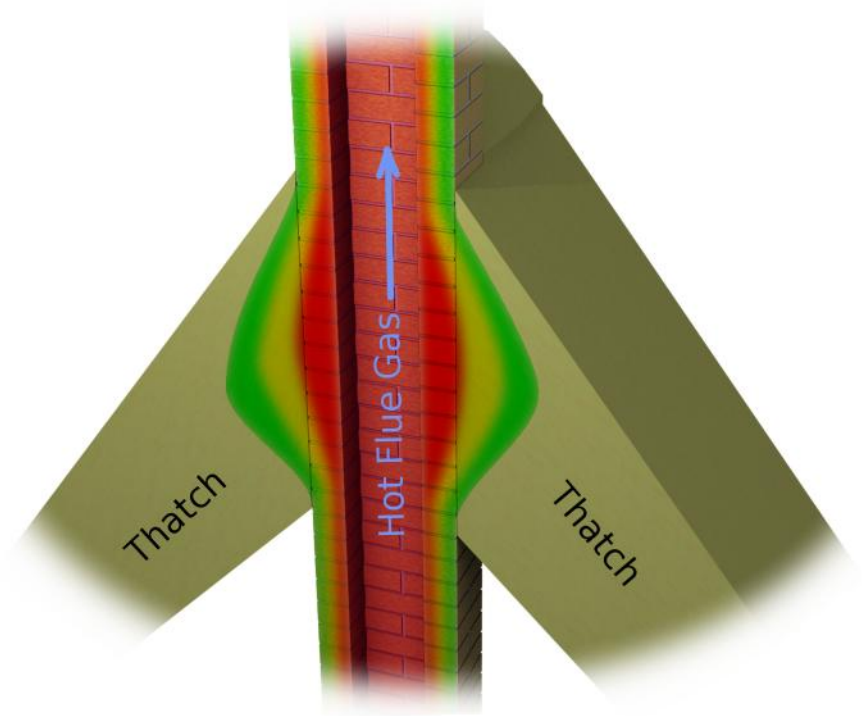

Figure 1 - Hot spots within the thatch

The size of the problem

With the annual cost to insurance companies for the repair or replacement of properties after a chimney related fire reportedly being in excess of £20,000,000.00 Insurance companies are becoming increasingly cautious about insuring thatched properties with multi-fuel or wood-burning stoves. Some HETAS registered engineers are being asked to carry out routine inspections and sign insurance forms stating that installations are safe; the possibility of litigation is becoming an increasing concern.

As a HETAS registered engineer the question is “what should you do if asked to work on a thatched property”. No doubt the first thought to come into some of your minds is, get the heck out of here or don't touch it with a barge pole. It doesn't have to be that way though as there are already adequate robust solutions if you follow the guidance in Approved Document J of the Building Regulations.

Compliance with Approved Document J of the Building Regulations

Firstly it should be noted that any work carried out on an appliance or chimney is notifiable to the local authority (usually via the HETAS compliance certificate). A material change of any part of the combustion system (appliance or chimney) will require the complete combustion system to be brought into compliance with current Building Regulations.

As thatch is a flammable material and there is usually a lot of it up against the chimney, a good place to start in Approved Document J is the requirements for distance to combustible material from the chimney. Paragraph 2.18 Separation of Combustible Materials from fireplaces and flues, states:

Combustible material should not be located where it could be ignited by the heat dissipated through the walls of fireplaces or flues. A way of meeting the requirement would be to follow the guidance in Diagram 21 so that combustible material is at least:

- A. 200mm from the inside surface of a flue or fireplace recess; or
- b. 40mm from the outer surface of a masonry chimney or fireplace recess unless it is a floorboard, skirting board, dado rail, picture rail, mantel-shelf or architrave.

Metal fixings in contact with combustible materials should be at least 50mm from the inside of the flue.

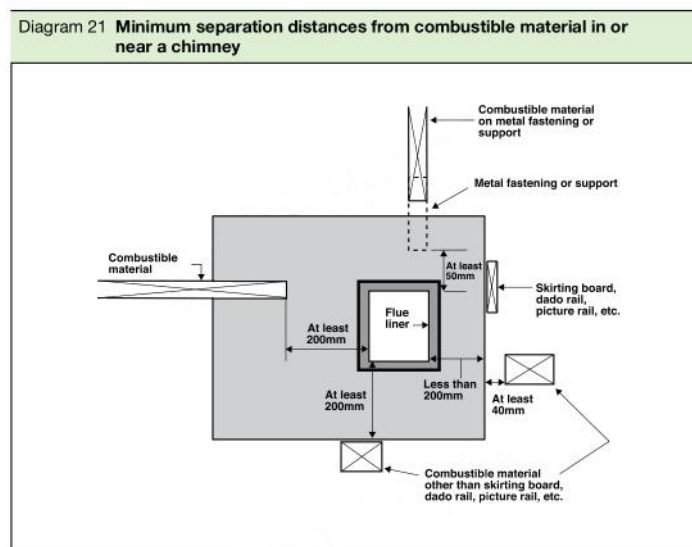

Figure 2 - Diagram 21 of Approved Document J

Relating the requirements of ADJ to a thatched chimney

Small single brick chimneys

On small traditionally constructed chimneys it is unlikely there will be sufficient room to add a flue liner and maintain the minimum required 200mm distance from the inside of the flue liner to the thatch of a tightly thatched chimney. In these situations with a traditional lining system the only option is to request the thatch be cut back away from the chimney before any work is started. Traditional lining systems include pre-manufactured clay, refractory concrete and pumice flue liners, cast in-situ concrete linings and twin-wall flexible metal liners.

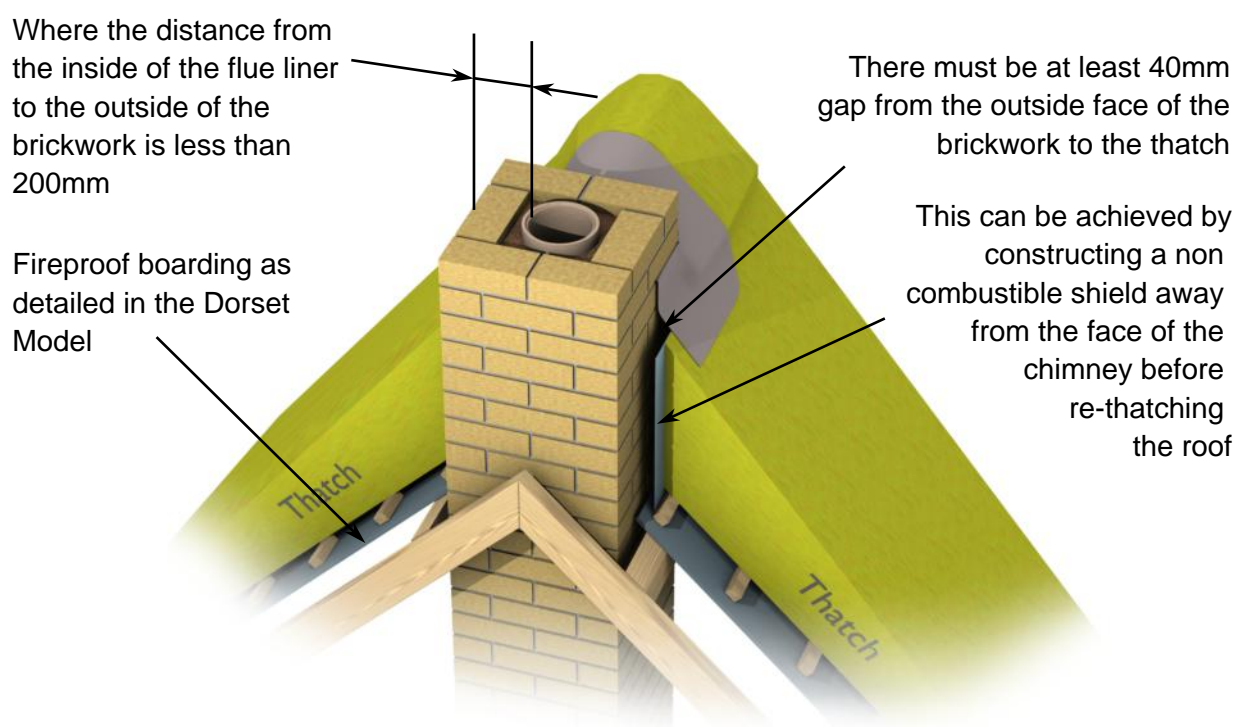

Figure 3 - Maintaining a 40mm air gap on small chimneys

To obtain the required 200mm distance to combustible material on a 150mm diameter lining, the external brickwork of the stack would need to be at least 550mm square, with the flue liner carefully centred. On a traditional 440mm square two brick stack, it is not possible to add a traditional liner and maintain the required distance to combustibles without adding the 40mm air gap to the outside of the stack.

Other options for lining the smaller chimney stack such as using a system chimney approach are discussed later.

Larger Chimneys

Where the distance from the inside of the flue liner to the outside of the brickwork is greater than 200mm

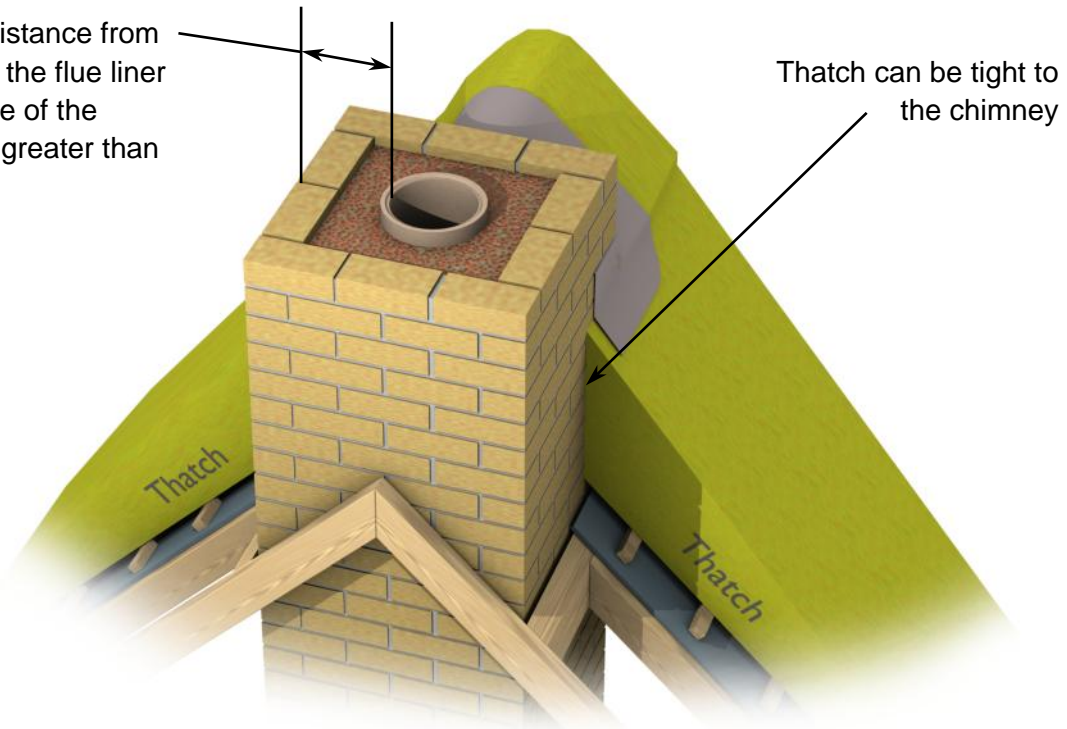

Figure 4 - Requirements on larger chimneys

On larger chimneys where a distance between the inner surface of the flue liner and outer surface of the chimney-stack of 200mm or larger can be achieved ADJ permits combustible materials to touch the outside of the brickwork. Great care however must be taken when relining a chimney to make sure that the 200mm dimension is maintained on all sides of the chimney that are in contact with combustibles. This is especially true of flexible lining systems such as twin-wall flexible stainless steel liners or the flexible former of cast in-situ concrete lining systems, which can snake within the chimney if care isn't taken to make sure they are correctly centred over their full length during the lining process.

If the liner snakes to a position closer than the allowed 200mm to combustibles, the chimney will not comply with ADJ and may cause a localised hot spot that can cause a fire.

It should also be noted that, when using twin-wall flexible stainless steel liners, different manufacturers have different instructions regarding insulation of the gap between the liner and brickwork of the stack. Some manufacturers insist on the void being filled with an insulating material to help maintain the temperature of the products of combustion and therefore improve the draw of the chimney. Other manufacturers require the void around their liners to remain clear of materials but closed off top and bottom. This type of liner does not offer a high thermal resistance so therefore does not add much to the insulation levels of the chimney. Chimneys on thatched properties relined with twin-wall flexible stainless steel liners must have the surrounding gap back filled with a suitable insulaton.

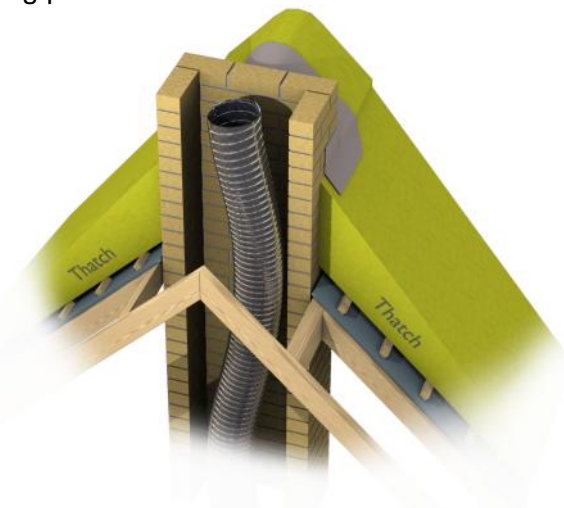

Figure 5 - Problems with flexible lining systems

Before any relining work is undertaken the existing chimney should be swept thoroughly, inspected and any remedial measures such as repairs to brickwork carried out. Relining should only be carried out when the chimney structure is repaired and returned to a good condition.

Back ventilation should not be used directly on the outside of any twin-wall flexible stainless steel liners as it can cool the flue gas reducing the flue draw and creating condensation problems within the flue.

Compliance with Building Regulations when traditional methods are not permitted

Quite often the option to strip back the thatch is not allowed because the local authorities conservation requirements prohibit removal or alteration of the thatch or the home owner won't permit changes to a sound roof. In this situation compliance with Building Regulations becomes substantially more difficult, though it is still possible in some circumstances.

System Chimneys

Fortunately a range of factory made system chimneys are available that have been tested to European Standards and have a declared distances to combustible materials. The system chimneys come in a range of sizes some of which are capable of fitting within a two brick stack (450mm square). System chimneys are available with stainless steel or ceramic liners surrounded by a high performance insulation and a stainless steel outer casing.

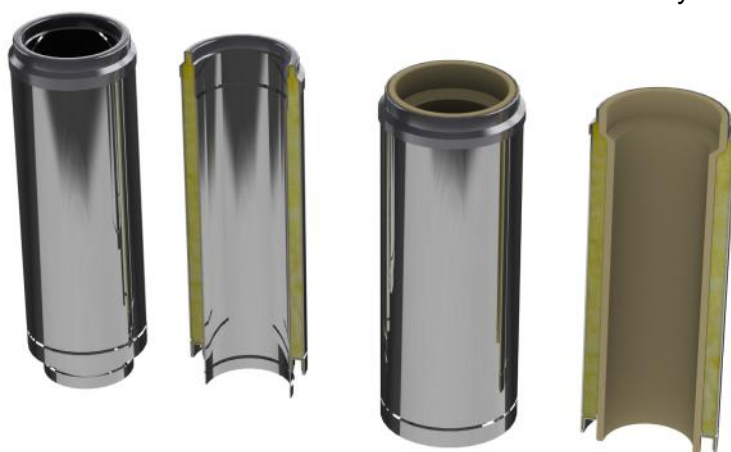

Figure 6 - Typical System Chimneys

European Chimney Designation

The system chimney will be provided with a designation that gives details of the systems capability. A designation such as T400 N1 D V3 L40040 Gxx signifies a chimney that is capable of operating at a normal working temperature of 400 degrees (T400), operating under natural draught (N1), non-condensing (D), with a corrosion resistance or material specification (V3 L40040) and being soot fire resistant (Gxx where xx will be a distance measurement signifying how close the nearest combustible materials can be to the outside of the system chimney casing). Though the test method for determining the distance to combustibles specifies a fully enclosed assembly, the standard allows products to be tested with ventilated firestops which significantly reduces the declared distance. It is important to seek advice from the manufacturer as to whether the system was tested with ventilated firestops as this is not apparent from the designation.

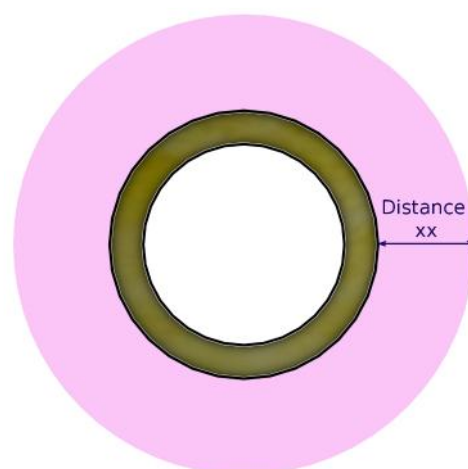

Figure 7 - Distance to combustibles

Distance to combustibles materials

Typical distances to combustibles are usually in the range from around 50mm to 100mm and if tested in a fully enclosed test assembly, will allow a small two brick chimney stack (450mm square) to be lined with a 150mm system chimney and still be compliant with the requirements of Approved Document J when the thatch is tight up against the brickwork. If the system chimney was tested with the test assembly ventilated then back ventilation must be provided into the stack. Because of the confusion between the test methods used by different manufacturers it would make sense to provide back ventilation every time system chimneys were used in this manner.

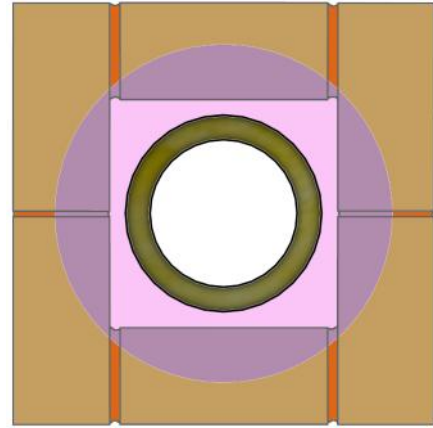

Figure 8 - Distance xx within brickwork

Back Ventilation to cool the chimney

If the chimney is straight it is simply a matter of assembling the system chimney and feeding it into the brick stack (special winching equipment may be necessary if the components are heavy). Care is needed to ensure each joint of the system chimney is tightly locked together and does not loosen during the installation. The system chimney will need to be supported as detailed in the manufacturers instructions, this may necessitate breaking into the stack to fit support brackets and to centralise the system chimney. With the system chimney in place it is possible to back ventilate the void between the system chimney and brickwork. Ideally the ventilation air should be ducted in from outside the building (as detailed in Figure 9 point a). If air is taken from the room the appliance is situated in, through a ventilated register plate (Figure 9 point b), this air has already been heated and therefore reduces the overall efficiency of the building and adds to the heating costs. A high level weatherproof vent should be provided in the chimney stack above the thatch, this will allow heated air to escape and stop the build up of heat within the brickwork of the chimney stack (Figure 9 point c). A camera access point should be provided to allow inspection of the system chimney.

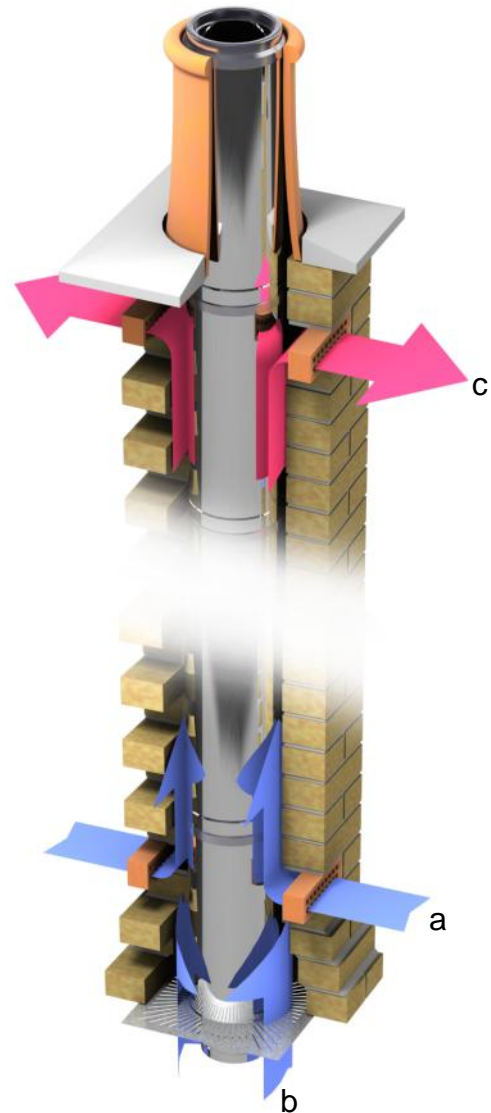

Figure 9 - Back ventilated system Chimney in brick stack

Adding a system chimney within a straight brick stack is a reasonably straight forward project, however if the existing chimney has offsets a whole new set of problems are created.

In order to comply on a single brick stack with thatch tight up to the brickwork of the stack a system chimney with a known distance to combustibles is required. The system chimney however won't feed around offsets or bends within the existing chimney stack. The chimney within the living area of the dwelling up to the bedroom ceiling, can be relined using one of the traditional lining techniques such as a suitable twin wall flexible lining, cast in-situ concrete lining or breaking into the stack and adding a clay, refractory concrete or pumice lining, making sure it is of the same diameter as the system chimney flue. At the bedroom ceiling level you will need to break into the brick stack. The system chimney should then be sealed to the traditional lining system. Depending on the type of systems used a closure plate and support brackets will be required. An air vent between the loft space and the void between the system chimney and brickwork should be provided together with a high level vent in the chimney stack above the thatch to provide back ventilation.

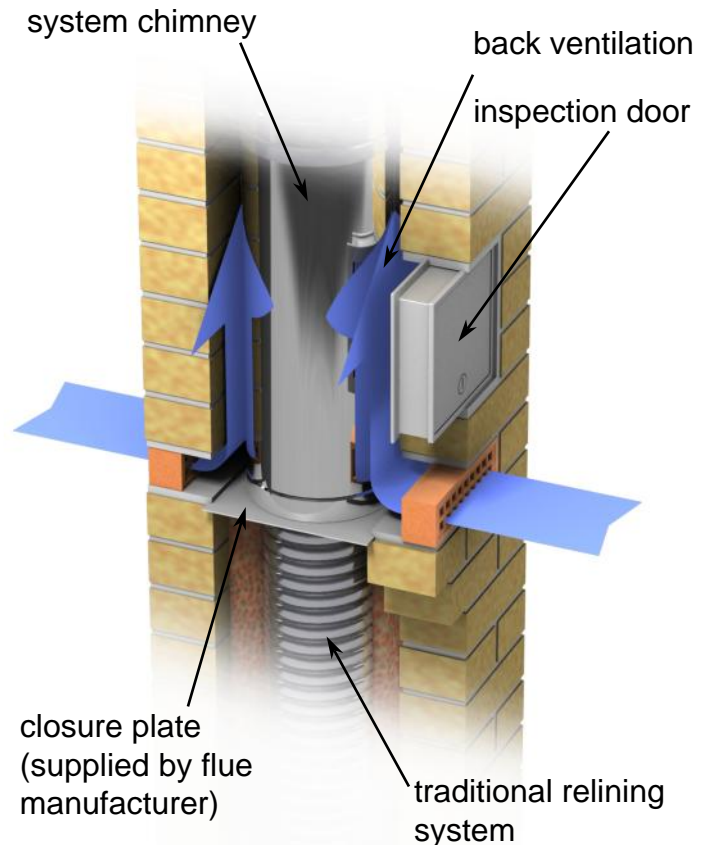

Figure 10 - Closure plate arrangement

It would also be good practice to provide an inspection hatch in the stack within the loft space so the externals of the system chimney can be inspected during maintenance checks on the combustion system.

The decision to proceed or walk away

If after surveying the chimney you feel you can comply with Building Regulations write a specification and sketch a design of your proposed solution; submit this to the home owners insurance company for their endorsement. Failure to get the insurance companies agreement to the work may invalidate the home owners insurance.

Finally ensure the home owner fully understands the requirements of, and how to operate the appliance safely, including the need to only use dry quality fuel and have regular maintenance carried out on the appliance and flue by registered competent engineers.

If you are in the situation where, due to conservation constraints, you are not permitted to add a 40mm gap between the thatch and brickwork, you are also prohibited from breaking into the existing stack to add a back ventilated system chimney and you are unable to obtain the required 200mm from the flue lining to the external brickwork of the stack; we can only suggest you walk away from the project, advising the home owner that a tested safe solution cannot be constructed due to the constraints imposed on you.

Further Information on Thatch Properties

National Society of Master Thatchers

The NSMT produce a number of useful guides to thatch including a booklet titled "Fire in Thatch – a Guide to its Prevention". Copies can be ordered from NSMT Secretary, 13 Parkers Hill, Tetsworth, Thame, Oxfordshire OX9 7AQ. E-mail: marjoriesanders@btinternet.com for details.

Dorset model for thatched buildings

The Dorset Model has been revised for 2009 after ten years as the main guidance for extensions and new buildings with thatched roofs that are within 12m of a boundary.

The Dorset Model is prescribed in Approved Document B of the Building Regulations when dealing with issues of external fire spread.

The Dorset Model can be downloaded from: <http://www.dorset-technical-committee.org.uk/>

This guide is provided to help explain the complexities of England and Wales Building Regulations Approved Document J with regards to distance to combustible materials around chimneys and their relation to the construction of thatched roofs.

The installation of both chimneys and heating appliances is governed by Building Regulations and British Standards. It is therefore the responsibility of the specifier, installer and user to ensure the products used and installation as a whole meets these requirements. This guides is provided to help explain only some of the requirements of the Building Regulations, it is not a substitute for them. HETAS cannot accept any liability for actions taken as a result of the information given in this guide.

HETAS registered installers must work within the confines of Building Regulations and can only self certify work that fully complies. In all other situations the Local Authority Building Control Officer must agree to and sign off the work.

Extracts from the Building Regulations ADJ are reproduced with permission of the Department of Communities and Local Government.

HETAS Limited
Orchard Business Centre
Stoke Orchard
Cheltenham
Gloucestershire
GL52 7RZ

Telepgone: 0845 634 5626
Facsimile: 01242673502
Email: info@hetas.co.uk
Web: www.hetas.co.uk

